

---

# PEARL ELECTRONIC DRUMSET



## Drum Set-Up Manual

Congratulations on your purchase! To get optimum performance of your E-PRO Live Drums, make sure to read this manual before set-up. This manual should be retained for future reference.

---

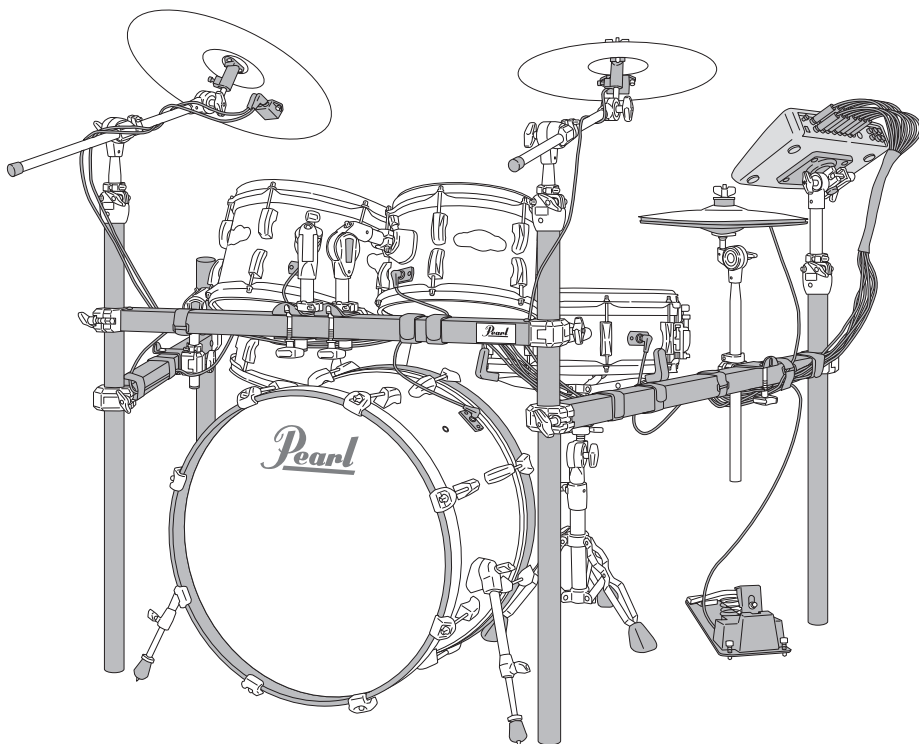

## SET-UP EXAMPLE (FRONT)

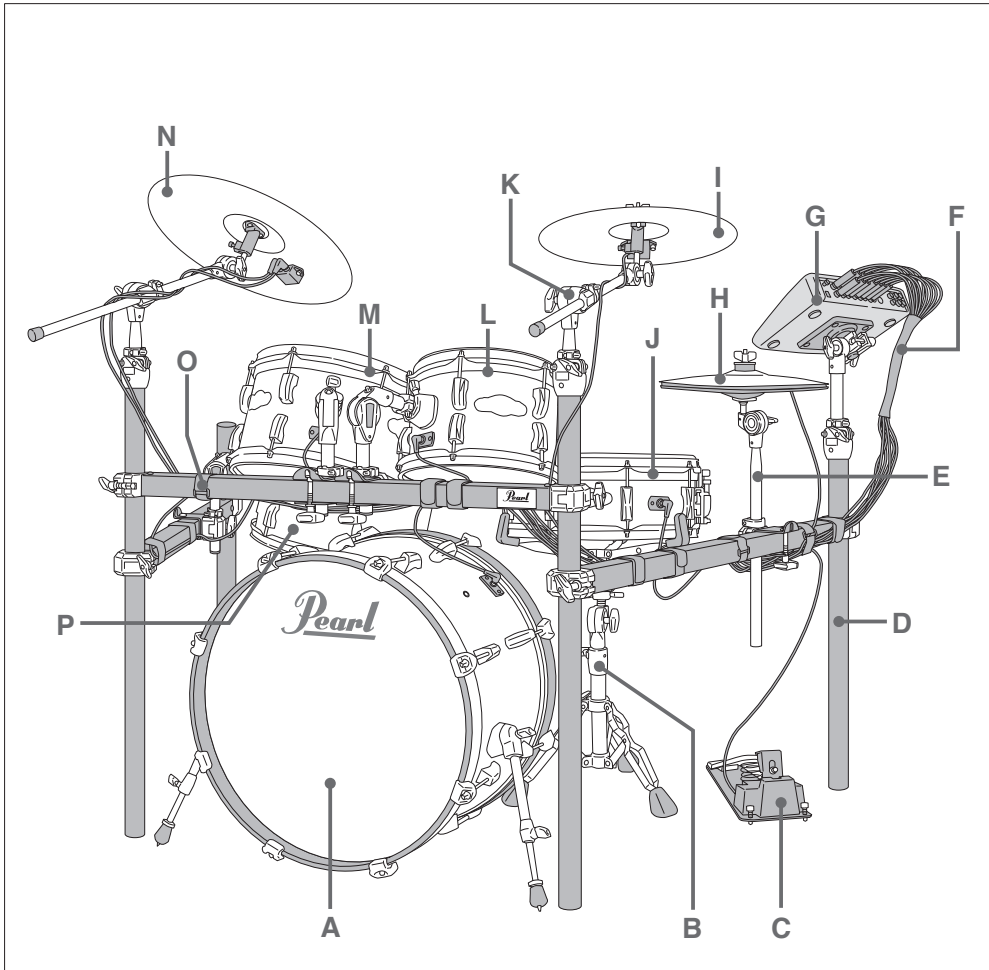

- |                            |                            |                          |
|----------------------------|----------------------------|--------------------------|
| <b>A</b> Bass Drum         | <b>G</b> r.e.d.box Module  | <b>L</b> 10" Tom Tom     |
| <b>B</b> Snare Stand       | <b>H</b> 12" Hi-Hat Cymbal | <b>M</b> 12" Tom Tom     |
| <b>C</b> Hi-Hat Controller | <b>I</b> 13" Crash Cymbal  | <b>N</b> 16" Ride Cymbal |
| <b>D</b> Drum Rack         | <b>J</b> Snare Drum        | <b>O</b> Velcro Strap    |
| <b>E</b> Hi-Hat Holder     | <b>K</b> Cymbal Holder     | <b>P</b> 14" Tom Tom     |
| <b>F</b> Cable Harness     |                            |                          |

## SET-UP EXAMPLE (BACK)

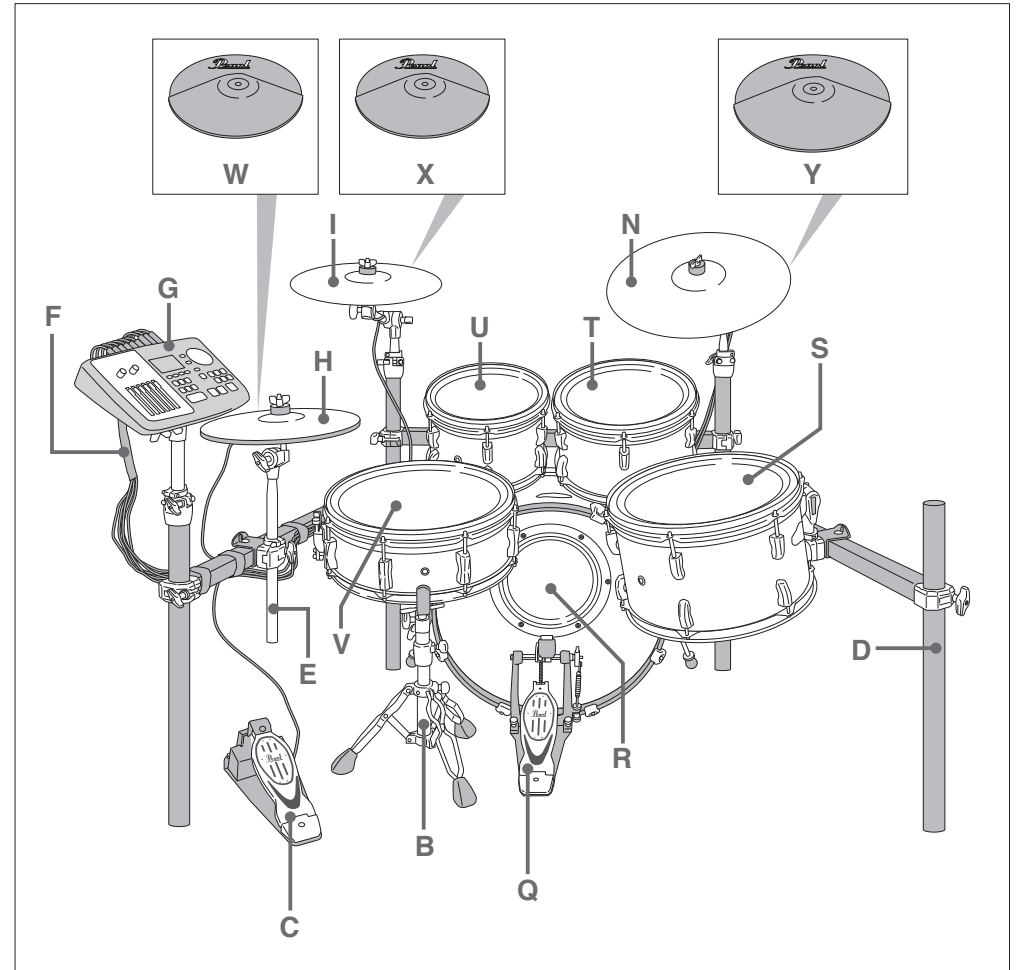

- |                                 |                                   |
|---------------------------------|-----------------------------------|
| <b>Q</b> Drum Pedal (Optional)  | <b>W</b> 12" Rubber Hi-Hat Cymbal |
| <b>R</b> Tru-Trac Bass Drumhead | <b>X</b> 12" Rubber Crash Cymbal  |
| <b>S</b> 14" Tru-Trac Drumhead  | <b>Y</b> 14" Rubber Ride Cymbal   |
| <b>T</b> 12" Tru-Trac Drumhead  |                                   |
| <b>U</b> 10" Tru-Trac Drumhead  |                                   |
| <b>V</b> 14" Tru-Trac Drumhead  |                                   |

## COMPONENTS / HARDWARE CARTON

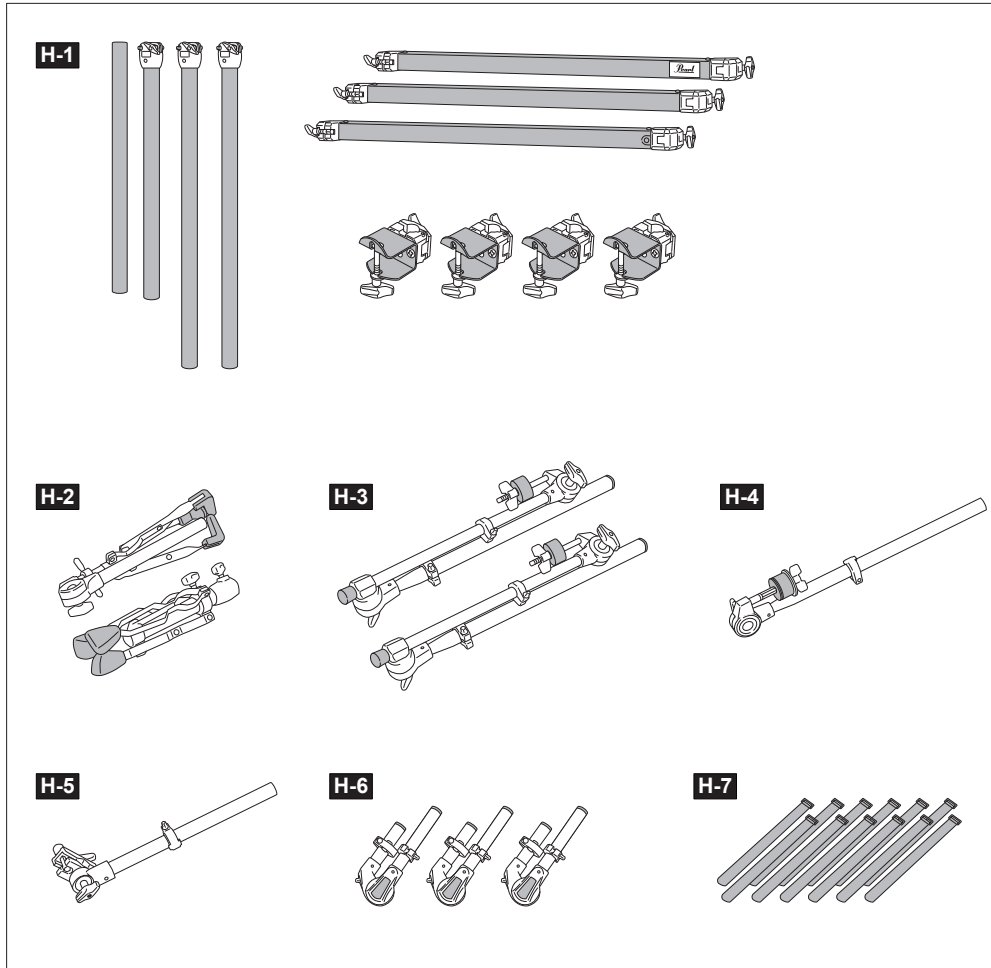

- H-1** Drum Rack (x1) / Includes : PC-8 Pipe Clamps (4)
- H-2** Snare Stand (x1) / S-790
- H-3** Cymbal Holders (x2) / CH-80E
- H-4** Hi-Hat Holder (x1) / CLH-80E
- H-5** Universal Clamp (x1) / UX-80
- H-6** Tom Holders (x3) / TH-900S
- H-7** Velcro Straps (x12) / NP-485

## COMPONENTS / DRUM CARTON

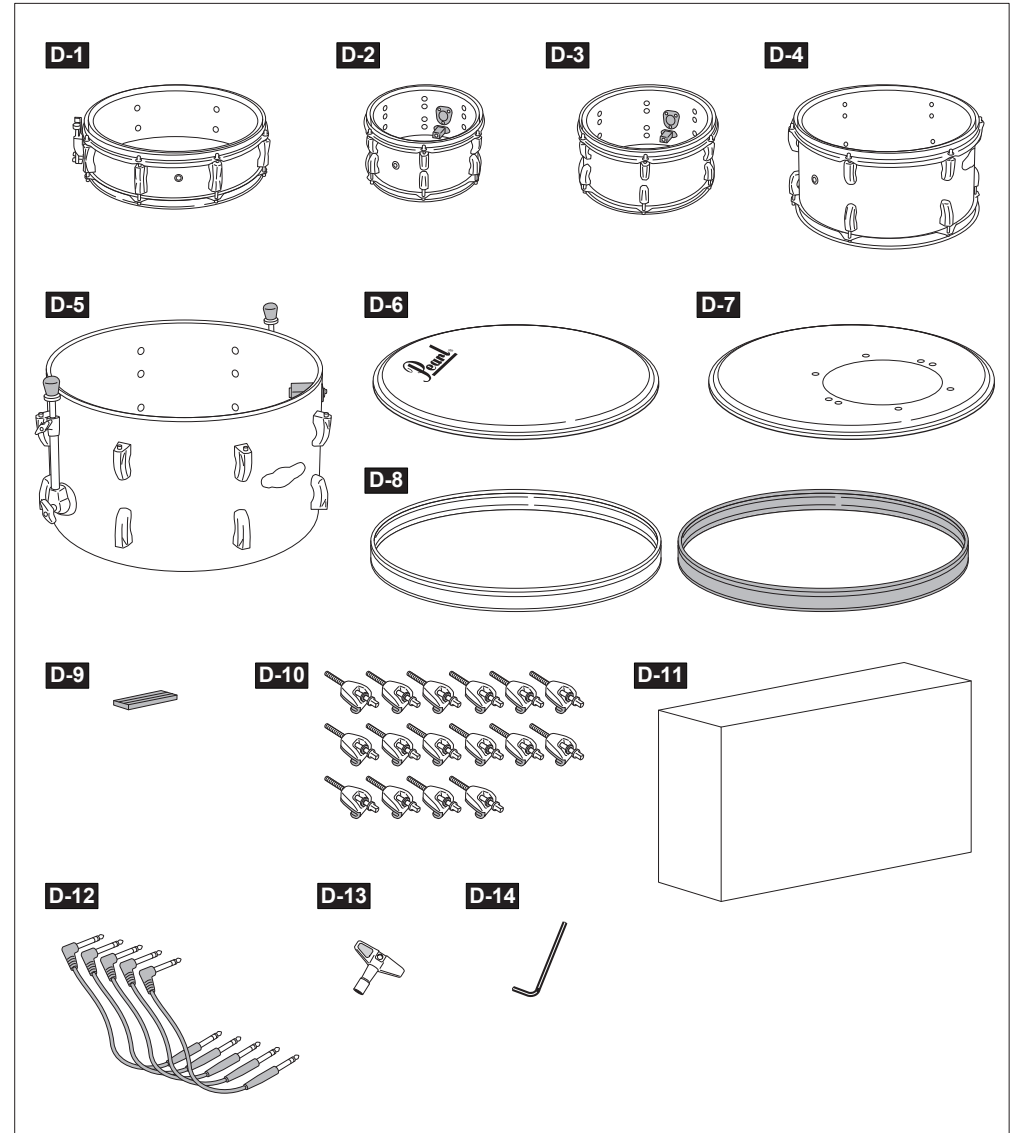

- D-1** 14"x 4.5" Snare Drum (x1) / EDD1445S
- D-2** 10"x 6.5" TomTom (x1) / EDD1065T
- D-3** 12"x 7" TomTom (x1) / EDD1207T
- D-4** 14"x 8" TomTom (x1) / EDD1408T
- D-5** 20"x 12" Bass Drum (x1) / EDD2012B
- D-6** Bass Drum Front Side Head (x1) / EBC-20F
- D-7** Bass Drum Batter Side Head (x1) / EBC-20EB
- D-8** Bass Drum Hoop (x2) / RIM-20RB
- D-9** Rubber Hoop Protector (x1) / NP-1
- D-10** Bass Drum Claws / CW-80  
Bass Drum Tension Rods / T-066X  
W7/32 x 110mm (x16)
- D-11** Bass Drum Cushion (x1) / NP-488L
- D-12** Jack Box Cables (x5) / CH-1JB
- D-13** Drum Key (x1) / K-050
- D-14** Hex Wrench(5mm) (x1)

## COMPONENTS / ELECTRONICS CARTON

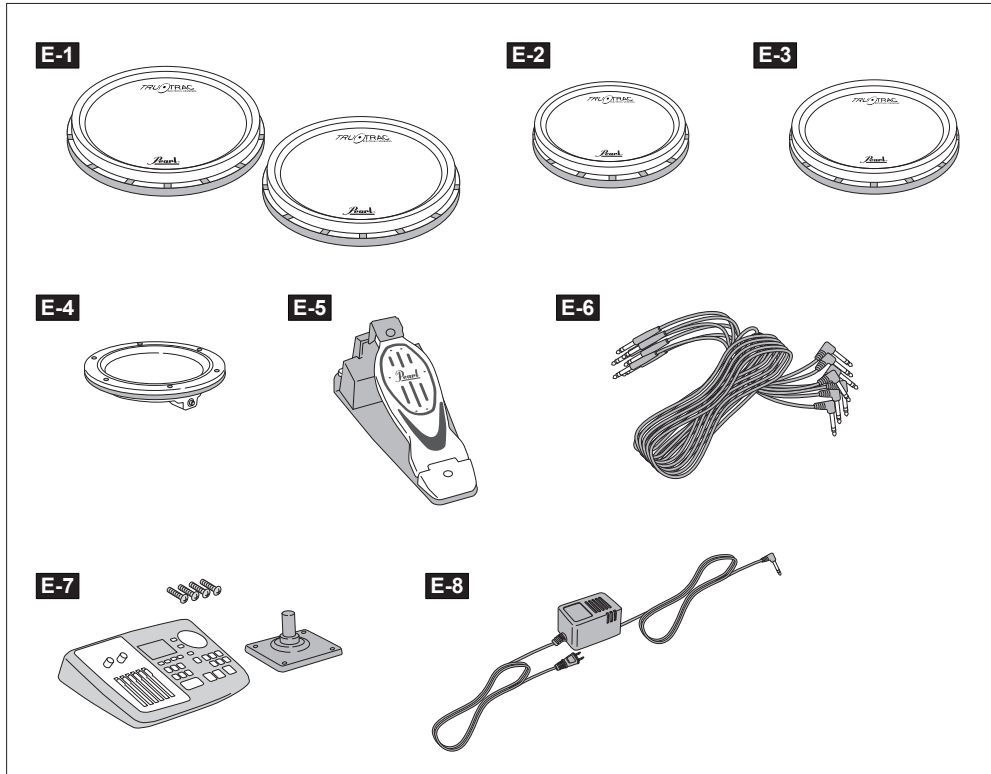

- E-1** 14" Tru-Trac Drumheads (x2) / TTP-14
- E-2** 10" Tru-Trac Drumhead (x1) / TTP-10
- E-3** 12" Tru-Trac Drumhead (x1) / TTP-12
- E-4** Tru-Trac Bass Drumhead (x1) / TTP-B
- E-5** Hi-Hat Controller (x1) / EHH-1
- E-6** Cable Harness (x1) / CH-10
- E-7** r.e.d.box Module & Mounting Bracket (x1) / RDM-20M/M
- E-8** Power Supply (x1)

## COMPONENTS / BRASS CYMBAL CARTON

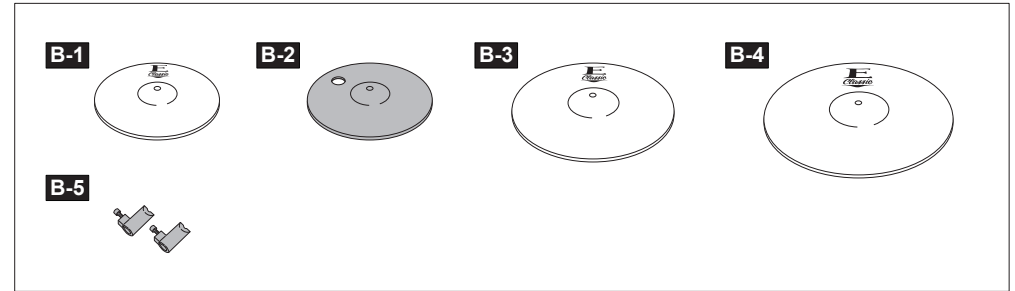

- B-1** 12" Brass Hi-Hat Cymbal (x1) / ECC-12S
- B-2** 12" Plastic Bottom Hi-Hat (x1) / ECC-12B
- B-3** 13" Brass Crash Cymbal (x1) / ECC-13D
- B-4** 16" Brass Ride Cymbal (x1) / ECC-16T
- B-5** Cymbal Mount (x2) / CM-1

## COMPONENT / RUBBER CYMBAL CARTON

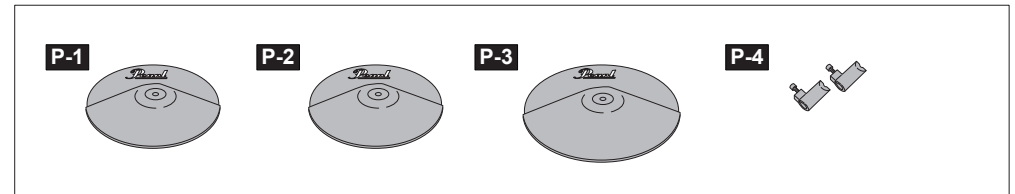

- P-1** 12" Rubber Hi-Hat Cymbal (x1) / EPC-12S
- P-2** 12" Rubber Crash Cymbal (x1) / EPC-12D
- P-3** 14" Rubber Ride Cymbal (x1) / EPC-14T
- P-4** Cymbal Mount (x2) / CM-1

## RACK ASSEMBLY

1. Locate the two "long" legs (each has a PCL-100 Pipe Bracket attached) and connect one to each end of the Front Bar (it has a Pearl logo badge) as shown (Fig. 1). Orient the Front Bar so that the "Pearl" logo on the clamps is facing right-side up for optimum stability (Fig. 1-A).

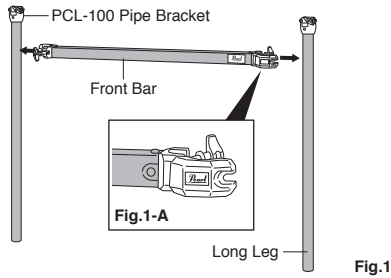

Fig.1

2. Connect a Side Bar to the left "long" leg as shown (Fig. 2) with the "Pearl" logo on the clamps facing right-side up for optimum stability (Fig. 1-A). Locate the "short" leg with a PCL-100 Pipe Bracket attached and connect it to the other end of the Side Bar as shown.

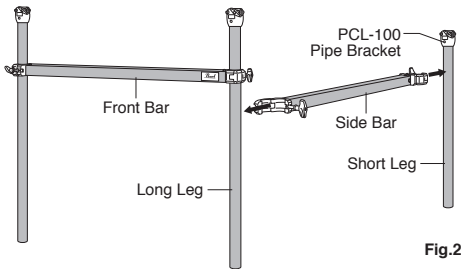

Fig.2

3. Connect the last Side Bar to the right "long" leg as shown (Fig. 3) with the "Pearl" logo on the clamps facing right-side up for optimum stability (Fig. 1-A). Connect the remaining "short" leg to the other end of the Side Bar as shown.

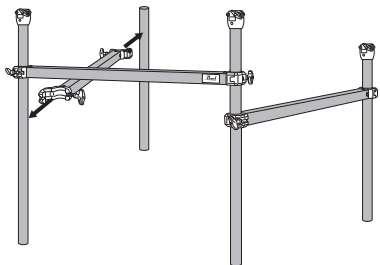

Fig.3

4. Adjust the height of the Front and Side Bars to your preference and make sure that all bars are leveled.

5. Attach two Pipe Clamps to the Front Bar and one each on both Side Bars (Fig. 4 and 4-A).

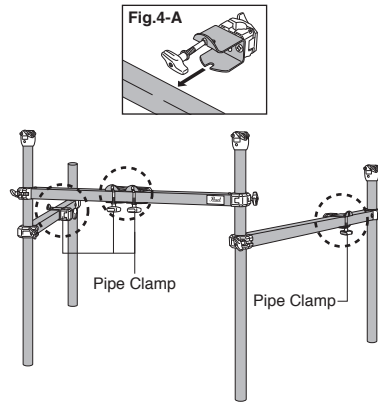

Fig.4

6. Attach the Tom Holders, Cymbal Holders, Hi-Hat Holder and the Universal Clamp to the Pipe Clamps and Pipe Bracket as shown below (Fig. 5).

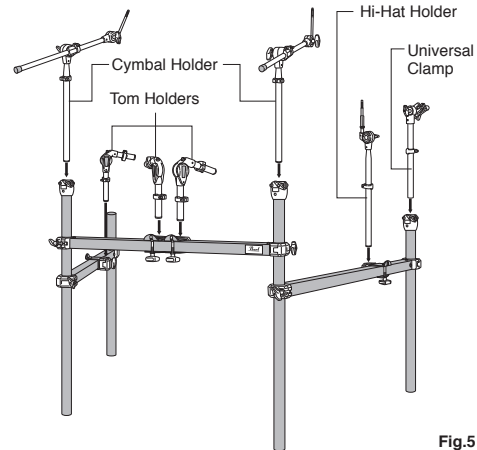

Fig.5

7. Reverse the position of the left and right Side Bars if you're left-handed.

### ⚠ Caution

\*Remove all components from the Pipe Clamps and Pipe Brackets before making adjustments to the height of the rack or position of the Pipe Clamps.

\*Securely tighten (don't over-tighten) all handle bolts on the Pipe Clamps and Pipe Brackets when the positions are finalized.

## TOMS AND SNARE DRUM ASSEMBLY

### 📌 Note

\*The bottom head on the Toms and the snare side head on the Snare Drum are pre-assembled at the factory.

1. Loosen the Tension Bolts on the batter side of the drum using the provided Drum Key and remove the Hoop (Fig. 6).

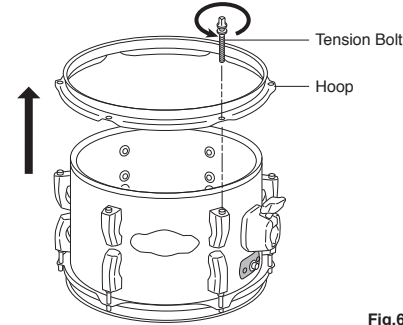

Fig.6

2. Locate the Tru-trac Drumhead that corresponds to the diameter of each drum.

**NOTE:** The two 14" Tru-Trac Drumheads are identical and either can be used on the 14" Tom or the Snare Drum.

3. Insert the "L" shaped end of the Jack Box Cable into the Jack on the underside of the Tru-trac Drumhead (Fig. 7).

4. Insert the other end of the Jack Box Cable into the Jack Box inside the shell (Fig. 7).

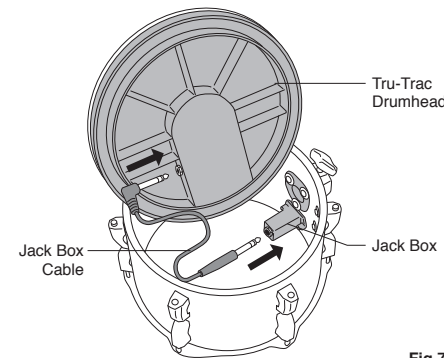

Fig.7

5. Place the Tru-Trac Drumhead on the shell and reattach the Hoop with the Tension Bolts (Fig. 8).

**NOTE:** The Jack Box Cables are short and have only limited reach. When assembling Toms, align the Tru-Trac logo with the BT-70 Tom Holder Bracket as shown (Fig. 8-A).

Similarly, when assembling the Snare Drum, align the Tru-Trac logo with the E-Pro Live Badge.

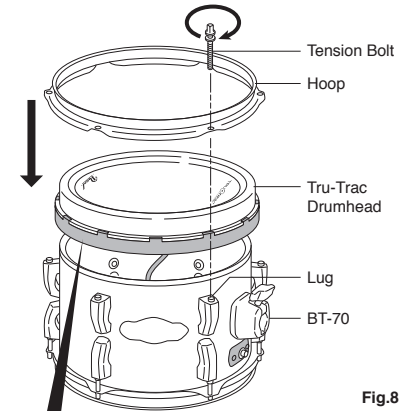

Fig.8

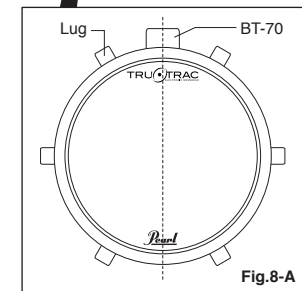

Fig.8-A

### 📌 Note

\*Tighten the Tension Bolts with only enough tension to hold the Hoop in place. Using greater tension can damage the plastic frame of the Tru-Trac Drumheads and void the warranty.

# TRU-TRAC BASS DRUMHEAD ASSEMBLY

**Note**  
 \*Do not remove the Tape until you have finished assembling the Tru-Trac Bass Drumhead to the Bass Drum Head (Fig. 9).

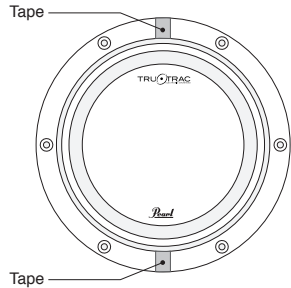

Fig.9

1. Unscrew the bolts on the Tru-Trac Bass Drumhead using the provided Hex Wrench and remove the Black Steel Hoop (Fig. 10).

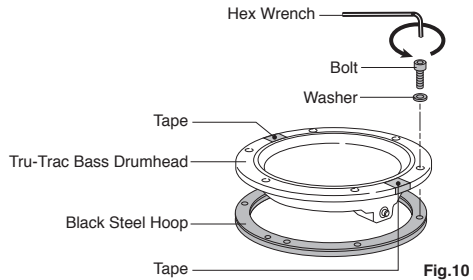

Fig.10

2. Peel off the protective sheet from the Rubber Gasket on the back of the Tru-Trac Bass Drumhead. Turn it over and place it on your hand (Fig. 11).

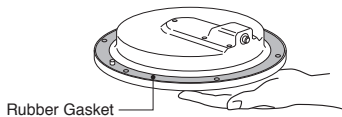

Fig.11

**Note**  
 \*Check the position of the screw holes and the 2 Guide Post holes on the Bass Drum Head before proceeding to the next step (Fig.12).

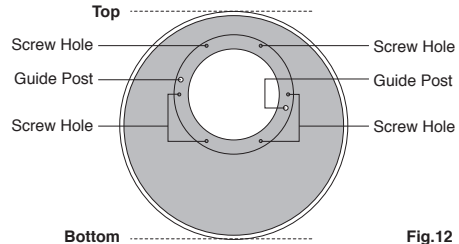

Fig.12

3. Place the Bass Drum Head over the Tru-Trac Bass Drumhead as shown making sure that the Guide Posts on the Tru-Trac Bass Drumhead are inserted into the corresponding guide holes in the Bass Drum Head (Fig. 13 & 13-A).

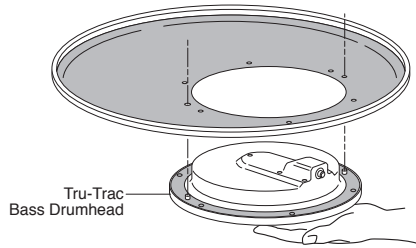

Fig.13

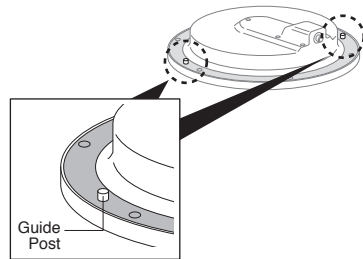

Fig.13-A

4. Place the Black Steel Hoop as shown making sure that the Guide Posts on the Tru-Trac Bass Drumhead are inserted into the corresponding guide holes in the Black Steel Hoop (Fig. 14). Hand tighten the bolts on the Tru-Trac Bass Drumhead from underneath.

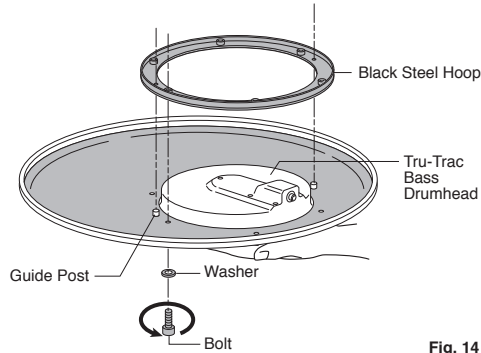

Fig. 14

5. Turn the Bass Drum Head over and tighten the bolts securely using the provided Hex Wrench. Remove the Tape from the Tru-Trac Bass Drumhead (Fig 15).

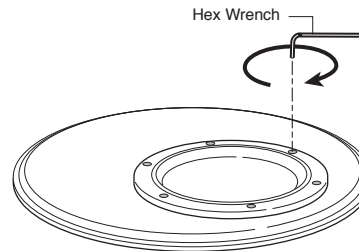

Fig. 15

**Note**  
 \*The Bass Drum Head will be floppy at this point but will become taut when attached to the shell and tightened.

**Hint**  
 \*The Rubber Pad on the Tru-Trac Bass Drumhead can be replaced easily with replacement rubber pad TTPB-1RB, sold separately .

## BASS DRUM ASSEMBLY

1. Place the Front Head on the Bass Drum shell as shown with the Pearl logo up and square the Pearl logo (Fig. 16). Place the Bass Drum hoop over the head with the flat side of the hoop facing down (Fig. 16-A). Hook a Tension Rod and Claw on the Hoop above each lug and tighten the Tension Rods using the provided Drum Key.

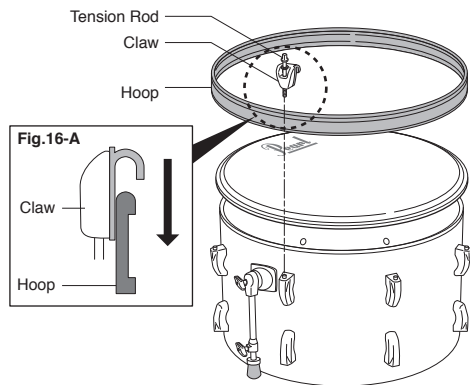

Fig.16

2. Turn the drum over and put the Bass Drum Cushion inside and at the bottom the Bass Drum Shell. Make sure that the Cushion doesn't touch the Jack Box inside the shell (Fig. 17).

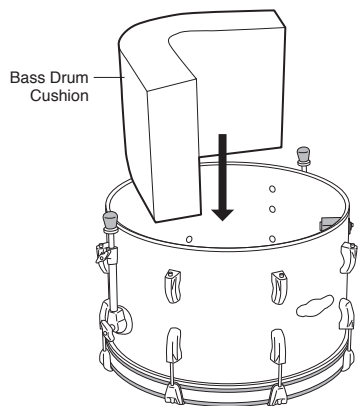

Fig.17

3. Insert the "L" shaped end of the Jack Box Cable into the Tru-Trac Bass Drumhead as shown and insert the other end of the cable into the Jack Box inside the Bass Drum shell as shown (Fig. 18).

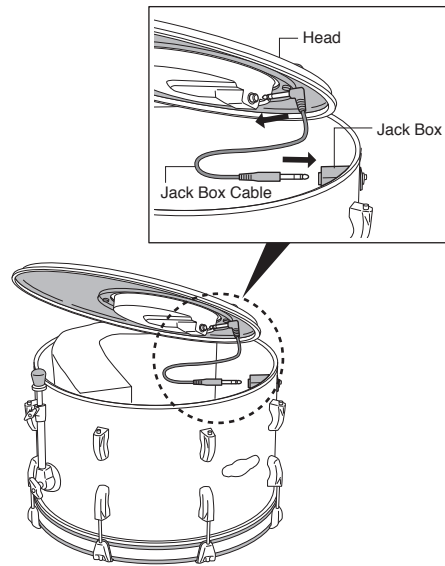

Fig.18

4. Place the Batter Side Head onto the Bass Drum shell with the Tru-Trac Bass Drumhead facing the top of the Bass Drum as shown (Fig. 19). Place the Bass Drum Hoop over the head with the flat side of the hoop facing down (Fig. 19-A).

5. Hook a Tension Rod and Claw on the Hoop above each lug and tighten the Tension Rods using the provided Drum Key (Fig. 19-A).

6. Attach the Hoop Protector on the batter side hoop where you attach your pedal (Fig. 19).

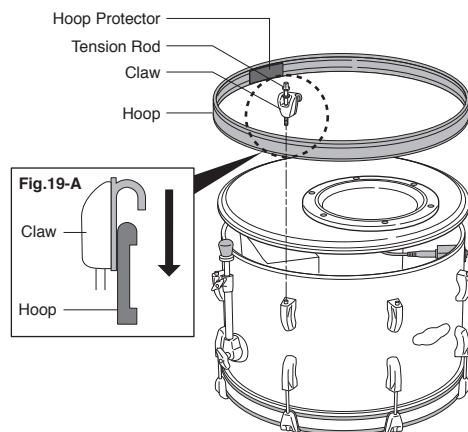

Fig.19

## DRUM SET-UP

### BASS DRUM

Position the Bass Drum upright and set the Bass Drum Spurs as shown with the front of the drum about an inch off the floor (Fig. 20).

The Bass Drum Spurs have spike tips (for added slip resistance) that can be exposed by turning the Lock Nut and Rubber Tip clockwise (Fig. 20).

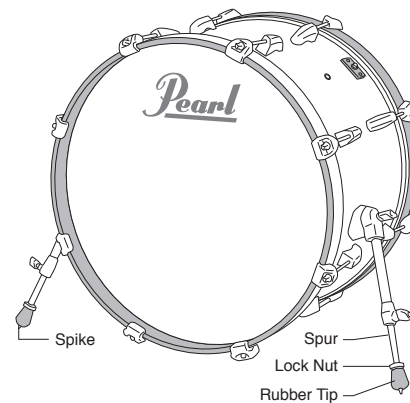

Fig.20

#### Warning

\*Use the spikes only on thick carpeted surfaces to prevent damage to the flooring underneath.

### SNARE STAND/DRUM

Open the legs of the stand to form a stable tripod and insert the Top Section into the base.

Open the Basket and adjust the Butterfly Nut as needed to accommodate the Snare Drum.

Place the Snare Drum into the Basket and tighten the Butterfly Nut to hold the drum securely (do not overtighten) (Fig. 22).

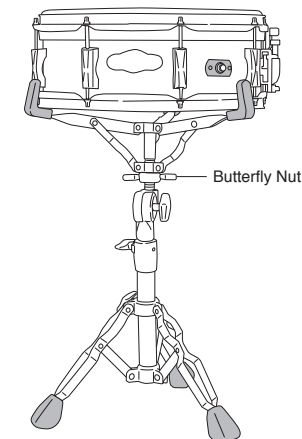

Fig.22

#### Caution

\*Make sure all bolts and nuts are tighten after setting.

### TOM TOM

Make sure that the Tom Holders and the Pipe Clamps are securely attached. Attach the Toms to the Tom Holders and position the height and angles to your preference. When done, set the tab on the StopLock into the slot in the Pipe Clamp and Tom Holder Bracket and tighten the Key Bolts with the provided Drum Key to retain the angle and height settings (Fig. 21).

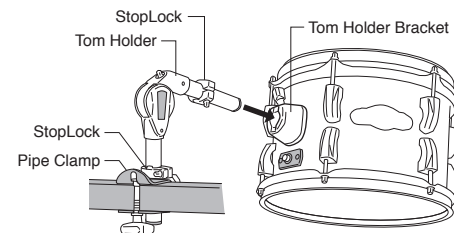

Fig.21

## r.e.d.box MODULE ASSEMBLY

1. Attach the r.e.d.box Mount to the bottom of the r.e.d.box as shown using a screwdriver. Do not overtighten (Fig. 23).
2. Insert the Mount into the Universal Clamp and tighten the Wing Nut (Fig. 24).

### Note

\*Keep the jaws of the clamp parallel.

3. Adjust the height and angle of the r.e.d. box Module to your preference.

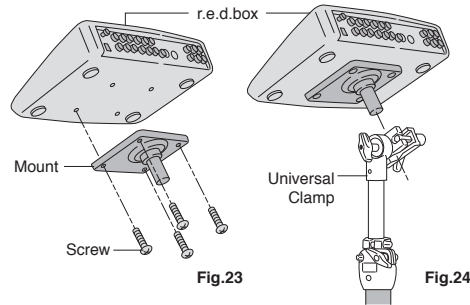

## CYMBAL HOLDER ASSEMBLY

1. Unscrew the Wing Nut on the Cymbal Holder and detach the Felt Washer. Put both aside for now.
2. Attach the Cymbal Mount onto the Cymbal Post and rotate the Attachment Screw until it's at a right angle to the Cymbal Holder Tilter as shown (Fig. 25).
3. Tighten the Attachment Screw with the provided Hex Wrench.

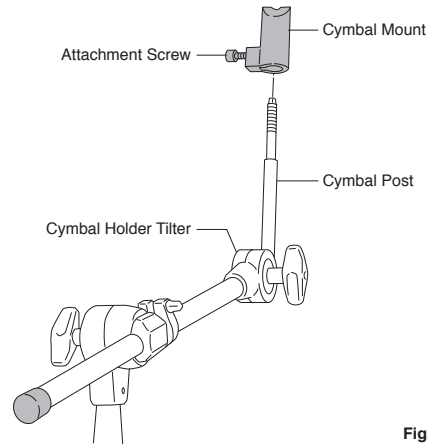

## WIRING THE CABLE HARNESS

**Note** \*The Cable Harness has two sides, one bundled together and the other separated.

1. Each cable is marked with the name of the component it connects to. Take the bundled side and match each cable to its corresponding jack on the back side of the r.e.d.box (Fig. 26).
- NOTE:** The Ride Cymbal has two Jacks. Make sure to insert the cables into the correct Jacks
2. Take the separated side and match each cable to its corresponding component.
  3. Use the provided Velcro Straps to secure the cables to the rack for a clean look.

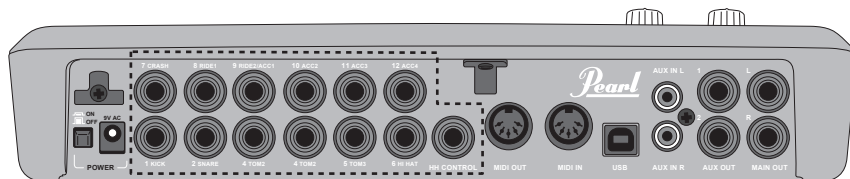

Fig.26

## WIRING AND MOUNTING CRASH/RIDE CYMBALS

1. Locate the Ride and Crash Cymbal and their matching cables and insert the cables into the corresponding jacks.

### Note

\*The Ride Cymbal has two Jacks. Make sure to insert the cables into the correct Jacks (Fig. 27-A).

2. Attach the Cymbal to the Cymbal Mount and attach the Felt Washer and Wing Nut in the order shown (Fig. 27). Make sure that the logo on the Cymbal is facing away from you to get maximum response from the cymbal.

### IMPORTANT

If you're using an EPC-14T Plastic Ride Cymbal, please read the section called "IMPORTANT NOTICE FOR EPC-14T PLASTIC RIDE CYMBAL USERS" on Page 2 in the RBM20 OWNER'S MANUAL for crucial trigger-setting information.

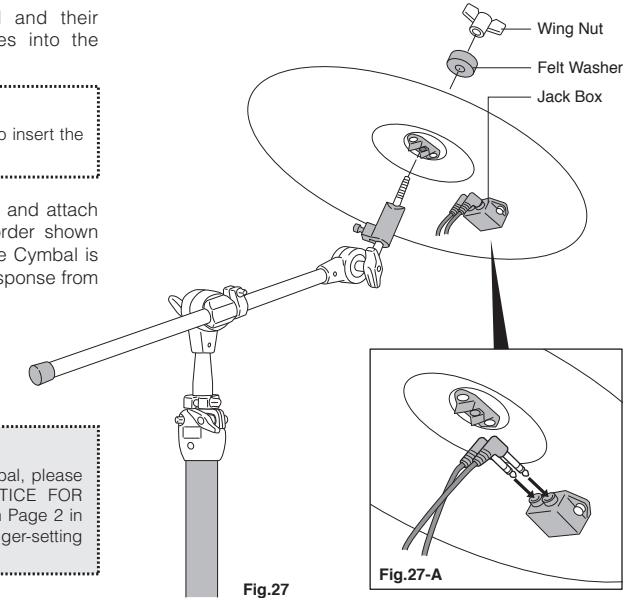

Fig.27

Fig.27-A

## WIRING AND MOUNTING RUBBER HI-HAT CYMBALS

1. Unscrew the Wing Nut on the Hi-Hat Holder and remove the Metal Washer and Felt Washer.
2. Arrange the Attachment and Support Washer in the order shown (Fig. 28).
3. Set the Rubber Hi-hat Cymbal on the Support Washer and Attachment as shown.  
**Note:** Make sure that they fit securely in the recess under the Rubber Hi-hat Cymbal.
4. Reattach the Felt Washer, Metal Washer and the Wing Nut in the order shown (Fig. 28) and tighten the Wing Nut to your preference.
5. Connect the Hi-hat cable into the Hi-hat Cymbal Jack.

### Note

\*The angle of the Hi-Hat Holder can be adjusted with the gear tilter to your preference.

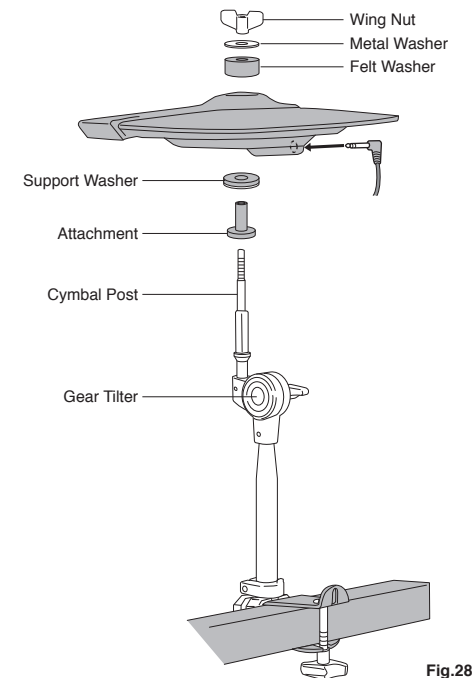

Fig.28



# WIRING AND MOUNTING BRASS HI-HAT CYMBALS

1. Unscrew the Wing Nut on the Hi-Hat Holder and remove the Metal Washer, Felt Washer and the Attachment.
2. Place the Bottom Plastic Cymbal on the Support Washer as shown and reattach the Attachment in the order shown (Fig. 29).
3. Pass the Hi-Hat Cable through the hole in the Bottom Plastic Cymbal as shown (Fig. 29) and plug it into the Jack under the Brass Hi-Hat Cymbal as shown (Fig. 29-A).
4. Assemble the Brass Hi-Hat Cymbal, Felt Washer, Metal Washer, and Wing Nut in the order shown (Fig. 29).
5. Tighten the Wing Nut to your preference.

## ⚠ Note

\*The angle of the Hi-Hat Holder can be adjusted with the gear tilter to your preference.

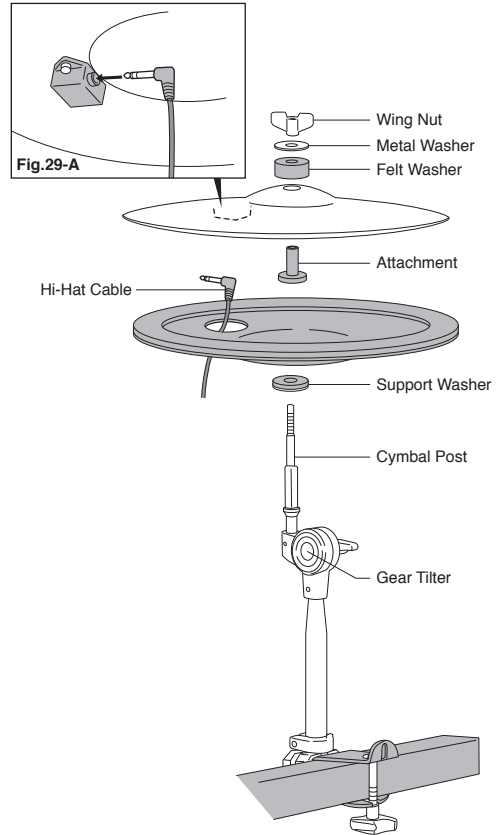

Fig.29

**Pearl**

<http://www.pearldrums.com>

Products and specifications are subject to change without notice.

Printed in Taiwan

-1007-